

Automated Vermicast Production Machine

Kathrine Tio¹

*Electronics Engineering Program
School of Engineering, Architecture, and Information
Technology Education, University of Saint Louis
Tuguegarao City, Cagayan*

Rustonel Vergara⁴

*Electronics Engineering Program
School of Engineering, Architecture, and Information
Technology Education, University of Saint Louis
Tuguegarao City, Cagayan*

Frynz Clyd Agustin²

*Electronics Engineering Program
School of Engineering, Architecture, and Information
Technology Education, University of Saint Louis
Tuguegarao City, Cagayan*

Ariel Lorenzo⁵

*Electronics Engineering Program
School of Engineering, Architecture, and Information
Technology Education, University of Saint Louis
Tuguegarao City, Cagayan*

Jayvee Castellon³

*Electronics Engineering Program
School of Engineering, Architecture, and Information
Technology Education, University of Saint Louis
Tuguegarao City, Cagayan*

Ertie Abana⁶

*Center for Engineering Research and Technology Innovation
School of Engineering, Architecture, and Information
Technology Education, University of Saint Louis
Tuguegarao City, Cagayan*

Abstract— Vermiculture is a fast way of converting wastes into organic fertilizer. It is an excellent soil enhancer and bioactive fertilizer for organic farming. Unfortunately, the conventional practiced by vermiculture farmers cannot guarantee to sustain the preferred worm activity. For this reason, an automated vermicasts production machine was built to maintain the environmental parameters required in the production of vermicasts without human intervention. The machine includes substrates shredder, watering system, harvester, soil sifter and is supported by the use of a microcontroller which receives data from the soil moisture and temperature sensors to monitor the environmental parameters. After conducting trials, it was evident that the vermicasts production machine was able to produce vermicasts. The watering system employed showed an efficient response on the unstable conditions of the vermibed. Apparent in the system was the operational monitoring of soil moisture and temperature which controlled the desired environment of the worm activity. With an initial vermiworm weight of 500 grams, the machine produced 2.5 kilograms of vermicasts and increased the worm production to 745 grams. The fish amino acid was also able to increase the vermiworm and vermicast production rate by enhancing the development and size of the African Nightcrawler. The machine yielded vermicasts with nutrient contents of 0.77% Nitrogen, 0.26% Phosphorus and 0.46% Potassium. With these nutrient contents, the machine is considered to be more desirable than the conventional method since it can produce more nutritive organic fertilizer for farmers.

Keywords—*vermiculture; vermicast; vermiworm; microcontroller; soil moisture sensor; temperature sensor*

I. INTRODUCTION

Fertilizers are essential in agriculture since many soils have very poor nutrient. Since soil nutrient greatly affects the quality of crops [1], most farmers use chemical fertilizers to ensure proper plant growth. However, chemical fertilizers may infiltrate the food chain through plant absorption producing undesired effects on humans and animals. Also, environmental complications such as soil degradation occur [2].

Development of relevant technologies such as recycling organic wastes reduces environmental stress which leads to the protection of the environment [3]. In recycling organic wastes, many people now practice vermiculture which is a sustainable approach in waste treatment [4]. Vermiculture is the process of fostering and breeding earthworms under restrained conditions. Rapid reproduction of earthworms can be achieved in vermiculture if artificial approving conditions are implemented [5]. Earthworms are used because it is regarded as one of the most significant soil invertebrate capable of giving beneficial effects on organic matter and physical properties of soil [6]. Moreover, the presence of earthworms prevents soil erosion by increasing the water holding capacity of the soil. The vermicast produced in vermiculture serves as a nutritive organic fertilizer and soil conditioner [5].

Today, farmers normally generate vermicast through manual operation. Although the underlying conditions in the entire production do not meet the optimum parameters to efficiently increase the performance of worms, sustaining each factor is difficult to accomplish for it involves continuous monitoring. With this in mind, a group of researchers [7] developed an automated production of African night crawler's vermicast with the android application. In their study, two

microcontrollers were utilized; one was intended for the signals obtained from the sensor networks for output generating activity. The other microcontroller is applied at the gate of worm bins. Sensors were also integrated into their system specifically: water level sensor, soil moisture sensor, light intensity sensor and ambient and soil temperature sensor. Watering system control was employed by the enabling and disabling flow of water through solenoid water valves. African Night Crawler cannot stand light intensity forcing them to migrate, for this purpose, the lamp was operated to aid worm relocation. However, the application of the lamp in their machine cannot certainly support worm migration for the reason that worms during and after composting do not remain on top of the bedding. Instead, the worms thrive under the vermicbed during the process of composting.

Considering that the employment of worm migration using lamp is ineffective, this study built a vermicast production machine to cater to worm migration without the means of light intensity. The machine includes a harvester that will initially separate the worms and vermicast which may tend to become sticky. Also, a soil sifter right under the harvester segregates carefully and slowly the worms from the vermicast without distressing and killing the worms. In addition, a substrate shredder was attached to finely strip the substrates for faster consumption of the worms. Another feature of this machine is the inclusion of fish amino acid simultaneously with the substrates to increase worm activity. Fish amino acid (FAA), is generated through fermentation of fresh fish parts together with brown sugar. Fermentation is considered to possess a valued reserve for agriculture [8]. This amino acid demonstrates progress to enhance the development and size when consumed by the microorganisms [9].

By automating the production of vermicast fertilizers, composting can be done with less human intervention and environmental parameters can be monitored more easily. Farmers can greatly save time and effort without tending to the composts every day. A farmer may better maintain worm activity and sustain worm's life with the use of more accurate sensors. In addition, communities can also produce their own fertilizers on a small scale with household organic wastes.

II. METHODS

Fig. 1 shows the interconnection of the materials and the primary components of the machine. To use the machine, initial bedding must be placed first in the vermibed along with the worms. The user needs to feed the worms with substrates that may include biodegradable materials preferably vegetables or leaves except for acidic fruits. Some substrates may need pre-decomposition. If a pre-decomposed substrate is used, then bedding may no longer be necessary. The substrates will be placed on the shredder compartment of the machine and be shredded. The shredded substrate will drop into the vermibed. Simultaneously, the vermibed will be poured with fish amino acid through the rubber hose with holes. The fish amino acid is transferred into the rubber hose with the use of the amino pump. In the vermibed, the moisture sensor measures the moisture of the vermibed while the temperature sensor measures the temperature inside the vermibed. The moisture and temperature values are shown in the Liquid Crystal

Display (LCD). Whenever the temperature reaches 33°C or the moisture drops below 60%, the microcontroller triggers the solenoid valve then to water the vermibed through the PVC pipe with holes. After some time, when the compost is consumed, the vermicast may be harvested. Once the harvester is turned on, the sifter will sway to easily screen out the worms that may come with the vermicast.

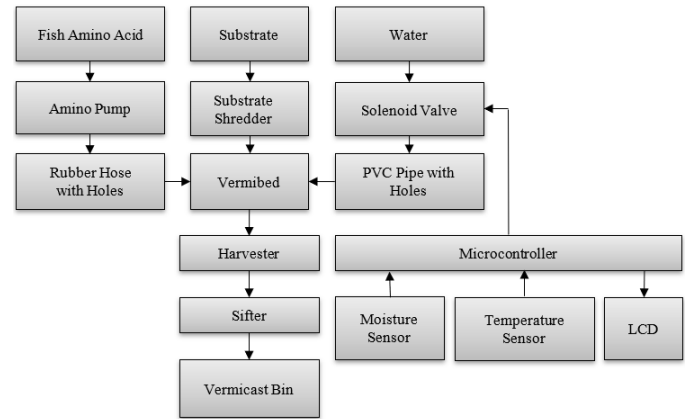

Fig. 1. Block diagram of the device.

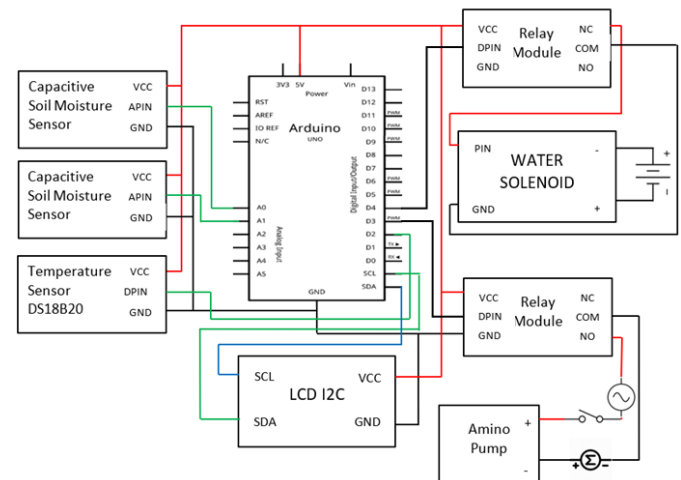

Fig. 2. Schematic diagram of the device.

Fig. 2 shows the connection of the electronic components used in the machine. The VCC and GND of the moisture sensors, temperature sensor, LCD display, and relay modules were all connected to the 5V and GND of the Arduino Uno microcontroller, respectively. The moisture sensor makes use of the analog pin of the microcontroller to send data while the temperature sensor uses the digital pin of the microcontroller. The SCL and SDA pin of the LCD is connected to the SCL and SDA pin of the microcontroller, respectively. The solenoid valve and the amino pump have different relay modules because they are powered differently. The solenoid valve used for controlling the water was powered externally with a DC supply since the Arduino Uno was not able to power it and which makes the sensors unstable. The amino pump was connected to another relay module and connected with the

shredder motor. The pump only functions when the switch is closed. The plug for the motor must be unplugged when not in use because it also affects the stability of the microcontroller and the sensors.

III. RESULTS AND DISCUSSION

A. Working Prototype

Fig. 3 presents the different perspectives of the complete and operating Automated Vermicast Production Machine. The machine is approximately 2.21 meters tall and is built in a vertical manner to achieve effective production of vermicasts and worm migration. The frame of the machine is made of wood and covered with light colored paint to provide good thermal insulation for the worms. The wood is also coated with putty and paint to make it water-resistant. The entire machine is designed for indoor grounds with caster roller wheel for better mobility.



Fig. 3. The vermicast production machine.

B. Testing Results

Table I shows the response during the lab testing of the watering systems on varied conditions. Primarily, the soil and temperature sensors will perceive the continuous conditions of the vermibed which will be the sole parameter to consider in the system. When the temperature is less than 33°C even if the moisture reading is acceptable, the vermibed will be poured with water. Likewise, when the moisture is below the accepted value regardless of the temperature reading, the system will work. However, no action can be done by the system if the conditions are attained.

TABLE I. RESPONSE OF THE WATERING SYSTEM OF THE MACHINE ON VARYING CONDITIONS

Trial	Moisture (%)	Temperature (°C)	Expected Action	Actual Action
1	26	27	Water	Water
2	35	26	Water	Water
3	53	26	Water	Water
4	45	26	Water	Water
5	10	35	Water	Water
6	28	35	Water	Water
7	17	36	Water	Water
8	43	34	Water	Water
9	62	34	Water	Water
10	56	34	Water	Water
11	62	27	No Action	No Action
12	67	25	No Action	No Action
13	66	26	No Action	No Action
14	65	24	No Action	No Action
15	63	24	No Action	No Action
16	72	25	No Action	No Action
17	70	25	No Action	No Action
18	69	26	No Action	No Action
19	66	27	No Action	No Action
20	67	24	No Action	No Action

During the vermicomposting, measurements on temperature and moisture were recorded. Table II shows that the automated method having a moisture of 62%-72% indicates that the environment was controlled. The automated machine was able to maintain the moisture needed in the worm activity through which worms thrive efficiently to moisture content with 60-80%. These results confirmed the findings of [7]. The machine was also able to provide a cooler environment from 24°C-27°C.

TABLE II. MOISTURE AND TEMPERATURE RECORDING IN THE MACHINE

Trial	Moisture (%)	Temperature (°C)
1	62	27
2	67	25
3	66	26
4	66	25
5	67	25
6	66	26
7	65	27
8	63	25
9	72	24
10	70	24
11	69	24
12	69	25
13	66	26
14	65	26
15	65	26

TABLE III. VERMICAST PRODUCTION

	Worms Produced		Vermicast Produced (kg)
	Initial (g)	Final (g)	
Conventional	500	600	2.1
Automated	500	745	2.5

The vermicast production of the machine was compared with the vermicast production using the conventional method for 15 days. Initially, 5kg of loam soil was used as bedding and 500 grams of African Nightcrawlers were introduced to both methods. Each setup was also given 6kg of green cabbage and lettuce, collected from the market, as substrates. The substrates were chopped into strips and set on top of the bedding in the conventional method while in the machine the substrates are placed in the shredder compartment of the machine. Using the machine, fish amino was additionally poured.

Table III shows the vermicast and vermiform production after the 15 days of vermicasting. As shown, more vermicast was harvested in the automated method compared to the conventional method. Subsequently, the production rate of vermiforms was calculated by weighing the worms in the two setups. The conventional production rate of vermiforms was calculated to be 20% more than the initial weight while the production rate of vermiforms of the machine yielded 49%. The results manifest that by increasing the worm activity through maintaining optimum conditions and incorporating fish amino acid, the production of vermicast increases and so with the vermiforms.

TABLE IV. NUTRIENT CONTENT OF THE PRODUCED VERMICAST

Sample	Nutrient Content		
	%Total Nitrogen	%Total Phosphorus	%Total Potassium
Vermicast Sample A (Automated)	0.77	0.26	0.46
Vermicast Sample B (Conventional)	0.66	0.36	0.32

Table IV presents the report of fertilizer analysis and moisture content of the two samples from automated and conventional system. The analysis shows that the machine produced a total of 1.49% of nutrient content which has a higher value than the conventional with a total nutrient content of 1.34%. An implication on market wastes as organic substrates in vermicomposting, specifically its major nutrients N, P and K are 0.45%, 0.25% and 0.18% respectively [10]. Therefore, the nutrient content gathered from the samples suggested a desirable result.

IV. CONCLUSION

This study developed an Automated Vermicast Production Machine which is an all-in-one machine that aids in the production of vermicast. It comes with a substrate shredder, amino acid pourer, automated watering system, and vermicast harvester with sifter. Based on results, it was proven that the machine provided a better environment than the conventional method. It also increased the produced vermicasts and improved the nutrient content of the vermicasts.

Based on the results of the study and tests conducted, the researchers recommend to make a comprehensive study on the various substrates that can greatly increase the worm activity and the nutrient content of the vermicast; improve the mechanization of the soil sieve or sifter to effectively separate the vermicast and vermiforms; and determine the time difference of the intake of substrates of vermiforms with pre-decomposed substrates in comparison to market waste.

REFERENCES

- [1] Mastro, R. E., Chhonkar, P. K., Singh, D., & Patra, A. K. (2007). Soil quality response to long-term nutrient and crop management on a semi-arid Inceptisol. *Agriculture, Ecosystems & Environment*, 118(1-4), 130-142.
- [2] Savci, S. (2012). Investigation of effect of chemical fertilizers on environment. *Apcbee Procedia*, 1, 287-292.
- [3] Rajendran, P., Jayakumar, E., Kandula, S., & Gunasekaran, P. (2008). Vermiculture and vermicomposting biotechnology for organic farming and rural economic development. *ECO Services International*, (February).
- [4] Hemalatha, B. (2013). Vermiculture for organic waste. *International Journal of Advanced Engineering Technology*, 4(1), 46-47.
- [5] Sheela, S., & Khimiya, S. (2013). Vermicompost to save our agricultural land. *Research Journal of Agriculture and Forestry Sciences* ISSN, 2320, 6063.
- [6] Adnan, M., & Joshi, N. (2013). The uniqueness of microbial diversity from the gut of earthworm and its importance. *J. Microbiol. Biotech. Res*, 3(1), 111-115.
- [7] Macabuhay, M. A., Abellera, M. T., & Ticsay, A. E. (2016). Development of an Automated Production of African Night Crawler's Vermicast with Android Application. In *Proceedings of the World Congress on Engineering* (Vol. 1).
- [8] Kim, J. K., Dao, V. T., Kong, I. S., & Lee, H. H. (2010). Identification and characterization of microorganisms from earthworm viscera for the conversion of fish wastes into liquid fertilizer. *Bioresource technology*, 101(14), 5131-5136.
- [9] Weinert, E. J., Miller, S. A., Ikeda, D. M., Chang, K. S., McGinn, J. M., & DuPont, M. W. (2014). *Natural Farming: Fish Amino Acid. Sustainable Agriculture, SA-12*. University of Hawaii, College of Tropical Agriculture and Human Resources, Honolulu 104p.
- [10] Pattnaik, S., & Reddy, M. V. (2010). Nutrient status of vermicompost of urban green waste processed by three earthworm species—*Eisenia fetida*, *Eudrilus eugeniae*, and *Perionyx excavatus*. *Applied and Environmental soil science*, 2010.